

Varenummer: 2307033311
Beskrivelse: E+G Håndhjul
VRTP.250-GXX2-A20

Mål

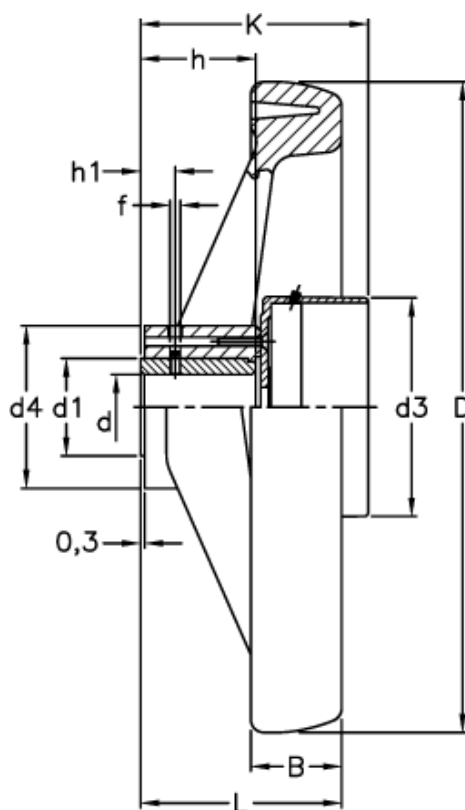

B	= 32	h1	= 12
D	= 250	K	= 74
d1	= 35	L	= 70
d3	= 76		
d4	= 58		
d H7	= 20		
f	= M8		
h	= 38		